

LOC	DIST	REVISIONS				
P	LTR REV	DESCRIPTION MODIFICATIONS	DATE	DWN DESS.	APVD APP.	
FH	2					
	I	CREATION	20MAR2007	FB	AG	
	A	MARKING MODIFICATION	08SEP2008	LP	AG	

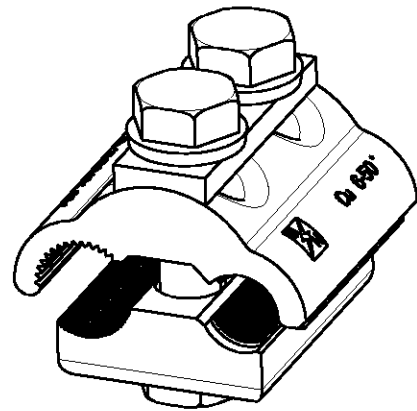
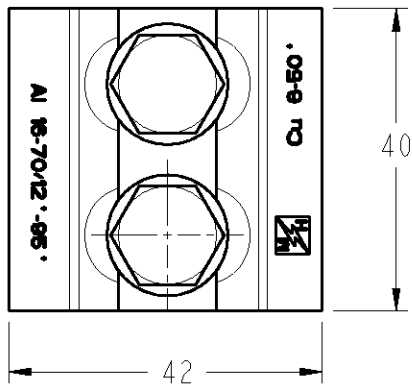
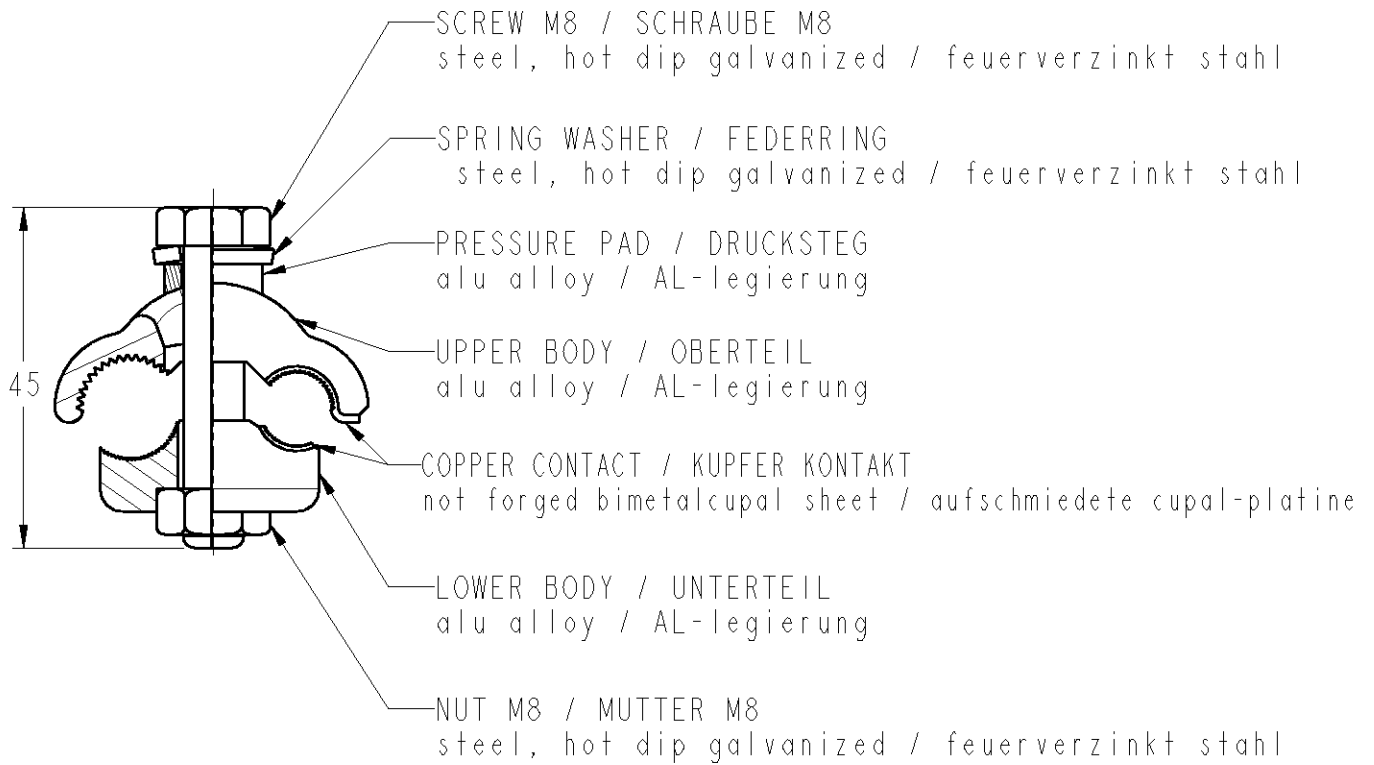

Capacity / Klemmbereich : 16-70 mm² AL
 6-50 mm² CU
 16/2.5-70/12 mm² AL/St

Tightening torque / Anzugsmoment : 22 N.m

TOLERANCES UNLESS OTHERWISE SPECIFIED	-
TOLERANCES NON SPECIFIEES:	-
FINISH	-
FINITION	-

DIMENSIONS:	mm
TOLERANCES UNLESS OTHERWISE SPECIFIED / TOLERANCES NON SPECIFIEES (SUIV. NB DE DECIMALES):	
0 PLC / DEC:	±0
1 PLC / DEC:	±0
2 PLC / DEC:	±0
3 PLC / DEC:	±0
4 PLC / DEC:	±0
ANGLES	±

DWN / DESSINE F. BOARD	20MAR2007
CHK / VERIFIE G. NEDELLEC	-
APVD / APPROUVE A. GUICHARD	-
PRODUCT SPEC SPEC. PRODUIT	-
APPLICATION SPEC SPEC. APPLICATION	-
WEIGHT MASSE APPROX.	- g

MATERIAL MATIERE	-
Tyco Electronics SIMEL PRODUCTS	
NAME TITRE	HEL-3909
SIZE FORMAT	A4
CAGE CODE	-
DRAWING NO No PLAN	C=1-1198999-9
RESTRICTED TO RESERVE A	-

CUSTOMER DRAWING / PLAN CLIENT	UNIQUEMENT POUR REFERENCE	SCALE ECHELLE	SHEET FEUILLE	OF DE	REV A
--------------------------------	---------------------------	---------------	---------------	-------	-------