

LOC		DIST		REVISIONS				
P	LTR REV	DESCRIPTION MODIFICATIONS			DATE	DWN DESS.	APVD APP.	
	FH	2						
	I			CREATION	21MAR2007	FB	AG	
	A			TIGHTENING TORQUE MODIFICATION	03FEB2009	LP	GS	

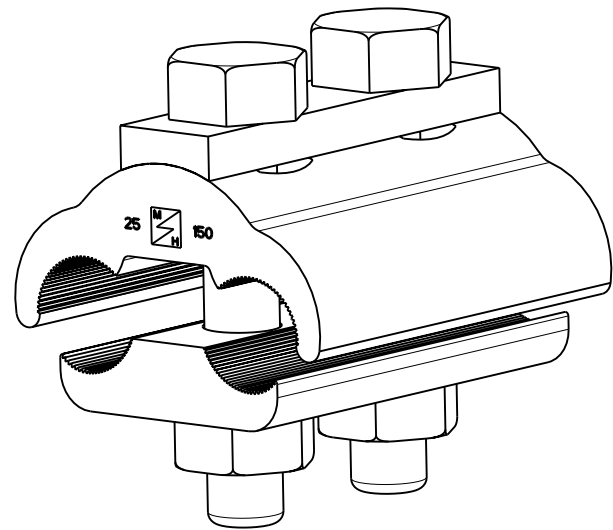
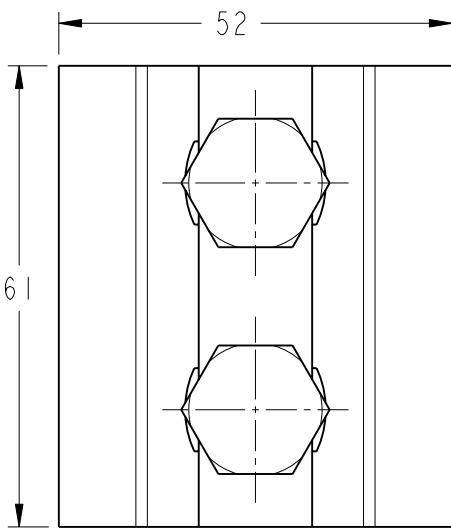
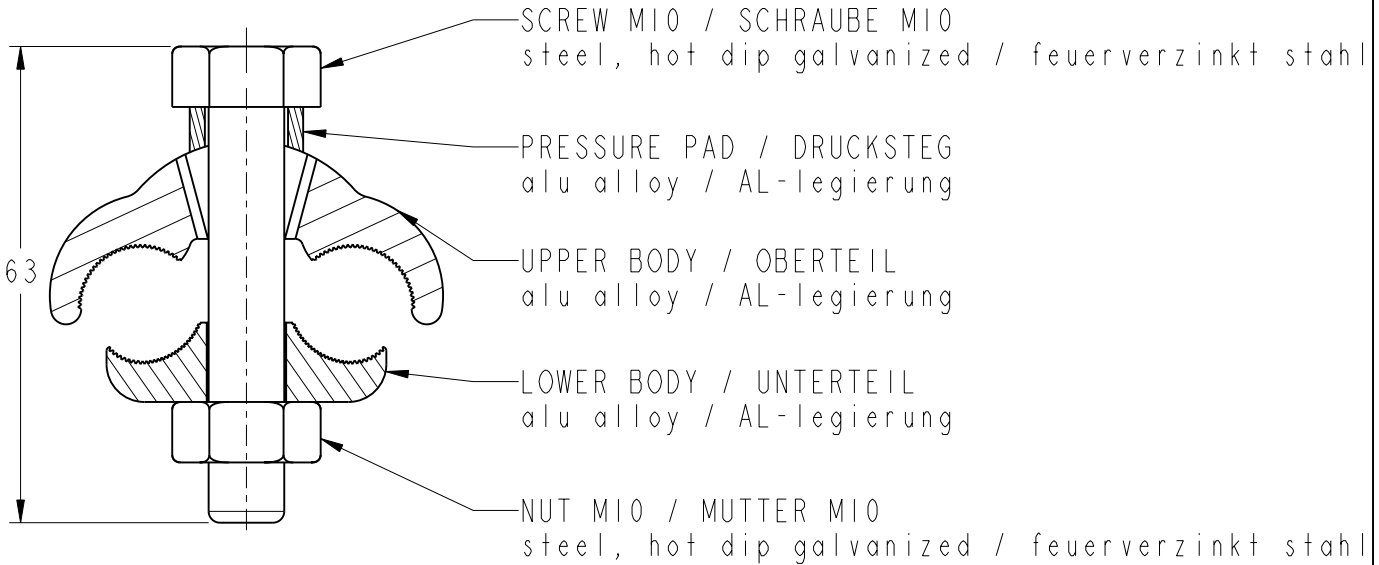

Capacity / Klemmbereich : AL/ST 25/4-120/20 mm²
 AL 25-150 mm²
 Tightening torque / Anzugsmoment : 44 N.m

20
 RELEASED FOR PUBLICATION
 LIBRE A LA DIFFUSION

THIS DRAWING IS UNPUBLISHED.
 DIFFUSION RESTREINTE
 BY TYCO ELECTRONICS CORPORATION ALL RIGHTS RESERVED.
 © COPYRIGHT 2009 BY TYCO ELECTRONICS CORPORATION. TOUS DROITS RESERVES.

DIMENSIONS: mm		DWN / DESSINE L. PETRIGNET 03FEB2009	MATERIAL MATIERE	TOLERANCES UNLESS OTHERWISE SPECIFIED TOLERANCES NON SPECIFIEES:
 TOLERANCES UNLESS OTHERWISE SPECIFIED: TOLERANCES NON SPECIFIEES (SUIVANT DE DECIMALES): 0 PLC / DEC: ±0 1 PLC / DEC: ±0 2 PLC / DEC: ±0 3 PLC / DEC: ±0 4 PLC / DEC: ±0 ANGLES ±- 		CHK / VERIFIE M. DOLLING	-	FINISH FINITION
		APVD / APPROUVE G. SCHWEIZER	-	-
		PRODUCT SPEC SPEC. PRODUIT	NAME TITRE	
		APPLICATION SPEC SPEC. APPLICATION	HEL-3592	
		WEIGHT MASSE APPROX. - g	SIZE FORMAT	RESTRICTED TO RESERVE A
			A4	
		CUSTOMER DRAWING / PLAN CLIENT	UNIQUEMENT POUR REFERENCE	SCALE ECHELLE :
			DRAWING NO No PLAN C-6-1199001-7	SHEET FEUILLE OF DE
				REV A