

REVISIONS					
P	LTR	DESCRIPTION	DATE	DWN	APVD
	A	Creation	23OCT2013	JD	AG
	B	ECR-14-011939	07AUG2014	JD	AG

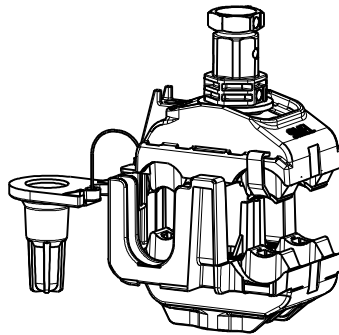
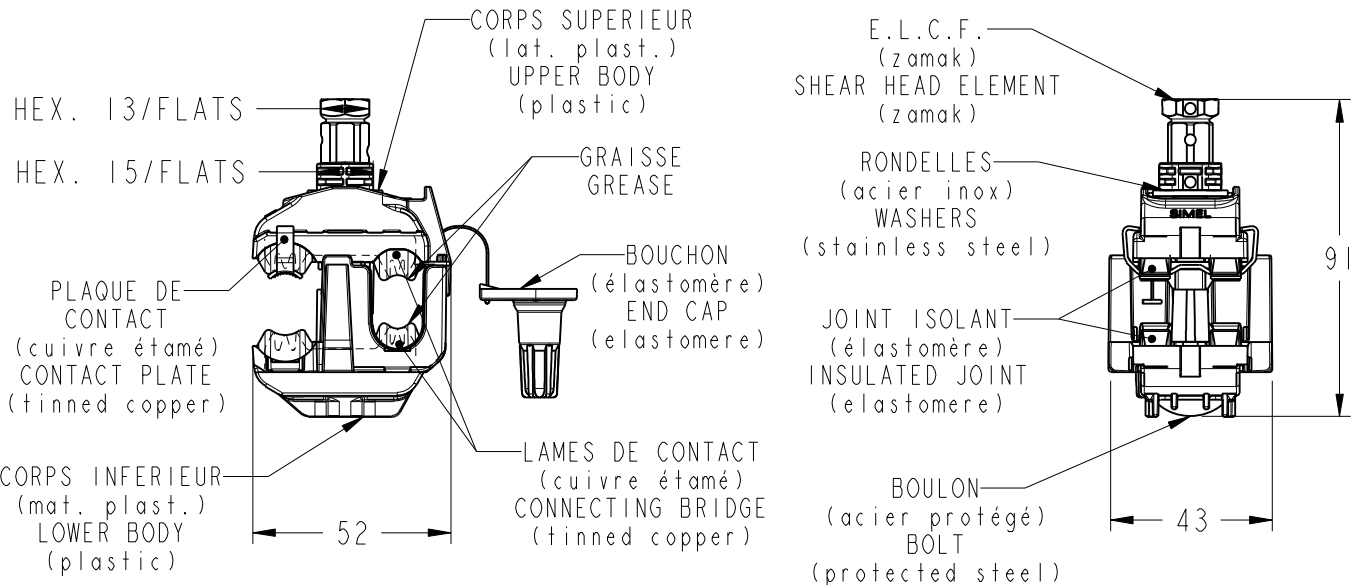

2107864-1  
PART NUMBER

DESIGNATION	PN	CODE	CAPACITES PRICIPAL CAPACITIES MAIN	CAPACITES DERIVES CAPACITIES TAP	MASSE WEIGHT	COUPLE DE RUPTURE BREAKING SHEAR HEAD TORQUE
P2B100 U Mk2	2107864-1		7mm <sup>2</sup> to 100 mm <sup>2</sup>	4 mm <sup>2</sup> to 35 (50) mm <sup>2</sup>	133g	11 Nm

MARQUAGE : LOGO, REFERENCE, CAPACITES, LOT  
MARKING : LOGO, REFERENCE, CAPACITIES, BATCH NUMBER

DIMENSIONS: mm	DWN J. Dossmann	23OCT2013	MATERIAL	-	FINISH	-
	CHK R. Buthiot	-	TE Connectivity			
TOLERANCES UNLESS OTHERWISE SPECIFIED:	APVD A. Guichard	-				
0 PLC ±0	PRODUCT SPEC	-	SIZE	CAGE CODE	DRAWING NO	RESTRICTED TO
1 PLC ±0	APPLICATION SPEC	-	A 4	-	C-C-2107864	-
2 PLC ±0	WEIGHT	-	CUSTOMER DRAWING			
3 PLC ±0			SCALE	SHEET	OF	REV
4 PLC ±0			1:2	1	2	B
ANGLES ±-						