

LOC		DIST		REVISIONS				
P	LTR REV	DESCRIPTION MODIFICATIONS		DATE	DWN DESS.	APVD APP.		
	0	CREATION		14-Jun-05	RB	DM		
	A	MISE A JOUR		20-Aout-10	GC	GN		

RELEASED FOR PUBLICATION

ALL RIGHTS RESERVED  
TOUS DROITS RESERVES

BY TYCO ELECTRONICS CORPORATION

© COPYRIGHT 2007

THIS DRAWING IS UNPUBLISHED.  
DIFFUSION RESTREINTE

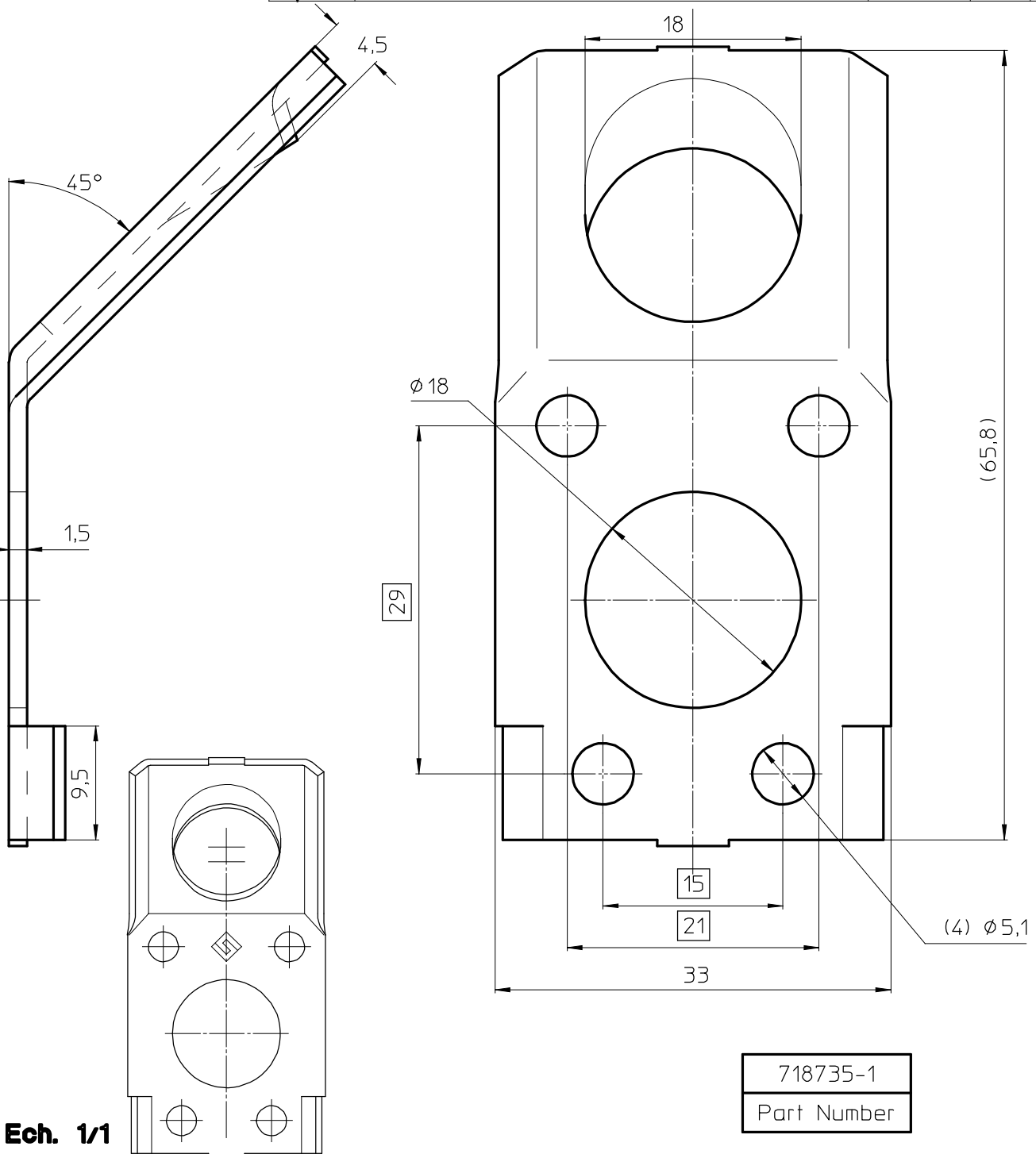

Ech. 1/1

718735-1  
Part Number

DIMENSIONS: mm	DWN /DESSINE R.BUTHIOT	MATERIAL MATIERE	Stainless Steel	FINISH FINITION	-
	CHK /VERIFIE E.DEREY	<b>Tyco Electronics</b> <span style="float: right;">SIMEL PRODUCTS</span>			
TOLERANCES UNLESS OTHERWISE SPECIFIED PER TOLERANCES NON SPECIFIEES SELON :	APVD /APPROUVE G.NEDELEC				
	PRODUCT SPEC SPEC. PRODUIT	SIZE FORMAT	A4	CAGE CODE	00779
	APPLICATION SPEC SPEC. APPLICATION	DRAWING NO No PLAN	© 718735		RESTRICTED TO RESERVE A
WEIGHT MASSE APPROX.	-	CUSTOMER DWG / PLAN CLIENT	UNIQUEMENT POUR REFERENCE	SCALE ECHELLE	2:1
			SHEET FEUILLE	1 OF 1 DE 1	REV A