

LOC	DIST	REVISIONS					
FH	00	P	LTR REV	DESCRIPTION MODIFICATIONS	DATE	DWN DESS.	APVD APP.
			B	CREATION	13NOV2008	LP	GN

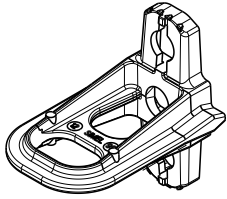

ECHELLE 1:4

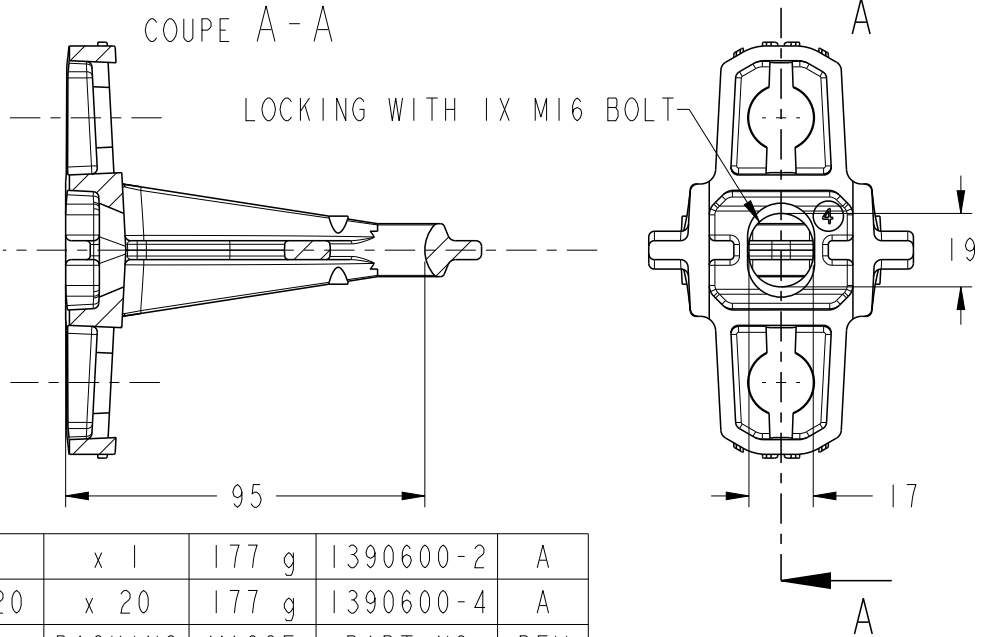

CA1500 3 TROUS	x 1	177 g	1390600-2	A
CA1500 3 TROUS x 20	x 20	177 g	1390600-4	A
DESCRIPTION	PACKING	MASSE	PART NO	REV

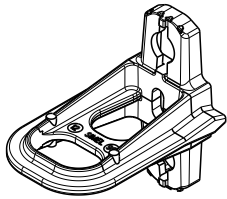

ECHELLE 1:4

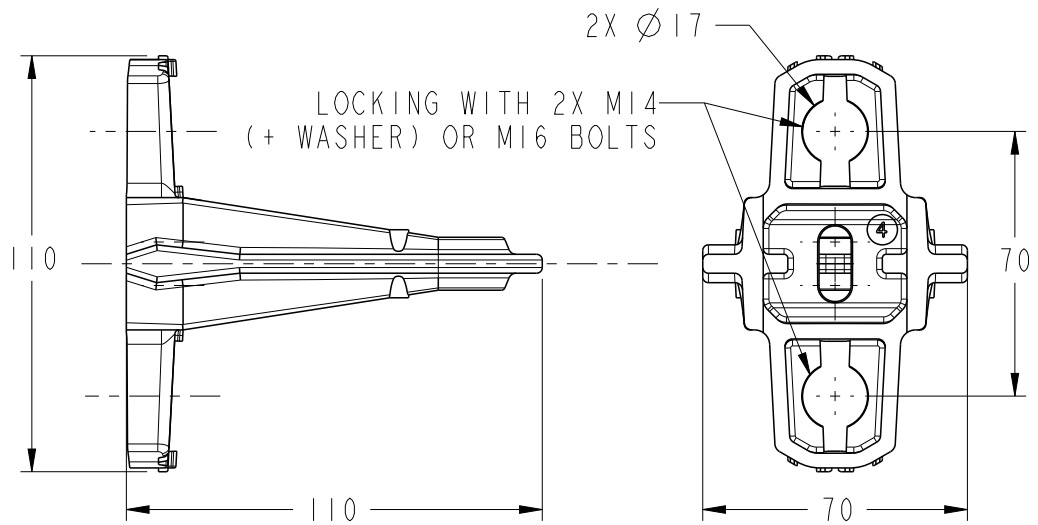

CA1500 2 TROUS	x 1	180 g	1390600-1	A
CA1500 2 TROUS x 20	x 20	180 g	1390600-3	A
DESCRIPTION	PACKING	MASSE	PART NO	REV

TOLERANCES UNLESS OTHERWISE SPECIFIED: -
 TOLERANCES NON SPECIFIEES: -

20
 RELEASED FOR PUBLICATION
 LIBRE A LA DIFFUSION

THIS DRAWING IS UNPUBLISHED.
 DIFFUSION RESTREINTE
 BY TYCO ELECTRONICS CORPORATION ALL RIGHTS RESERVED.
 TOUS DROITS RESERVES.
 COPYRIGHT 20

DIMENSIONS: mm	DWN /DESSINE L. PETRIGNET 13NOV2008	MATERIAL MATIERE ALU ALLOY	FINISH FINITION -	
TOLERANCES UNLESS OTHERWISE SPECIFIED: TOLERANCES NON SPECIFIEES (SUIVANT DE DECIMALES): 0 PLC /DEC: ±0 1 PLC /DEC: ±0.1 2 PLC /DEC: ±0.2 3 PLC /DEC: ±0.3 4 PLC /DEC: ±0.4 ANGLES ±-	CHK /VERIFIE L. MAINIER	SIMEL PRODUCTS		
	APVD /APPROUVE G. NEDELLEC			
	PRODUCT SPEC SPEC. PRODUIT	NAME TITRE CA1500	SIZE FORMAT A4	CAGE CODE -
	APPLICATION SPEC SPEC. APPLICATION	DRAWING NO No PLAN C-1390600	RESTRICTED TO RESERVE A -	
WEIGHT MASSE APPROX. - g	CUSTOMER DRAWING /PLAN CLIENT UNIQUEMENT POUR REFERENCE SCALE ECHELLE 1:2 SHEET FEUILLE 1 OF DE 1 REV B			